

INSTRUCTION MANUAL

BP-355

Wood Band Saw (240V)

345mm throat x 245mm Height Capacity



W4224

8/2/07

(W4224)

Manual

HAFCO BP-355

14" Heavy Duty Band Saw

Model: MJ3435

MACHINERYHOUSE

Please read this manual carefully before operation!

1 Contents

- 1.contents
- 2.please read first
- 3.specification
- 4 safety
 - 4.1 general safety instructions
 - 4.2 specific safety instruction for band saw
 - 4.3 symbols used throughout these instructions
- 5.unpacking
- 6.troubleshooting
- 7.assembly
 - 7.1 1 initial assembly
 - 7.2 setting instructions
 - 7.3 no volts emergency stop switch
- 8. operating
 - 8.1 operating instructions
 - 8.2 using the mitre gauge
 - 8.3 tilting the table to perform bevel cuts
 - 8.4 making freehand and radius cuts
- 9. adjustments & maintenance
 - 9.1 changing the blade speed
 - 9.2 replace the drive belt
 - 9.3 changing the blade
 - 9.4 maintenance
- 10. wiring diagram
- 11.diagram & parts list

2 Please Read First

WARNING!

When using electric tools basic safety precautions should always be followed to reduce the risk of fire, electric shock and personal injury including the following

- Read these instructions before attempting to operate this product and save these instructions.
- If you notice transport damage while unpacking, notify your supplier immediately. Do not operate the saw!
- Dispose of the packing in an environmentally friendly manner. Take to a proper collecting point
- Keep these instructions for reference on any issues you may be uncertain about.

ATTENTION:



FOR YOUR OWN SAFETY, READ AND UNDERSTAND THE OWNER'S MANUAL BEFORE OPERATING MACHINE

1. Set up the saw on a firm, level, non-slip, vibration-free base. Keep the site free of tripping hazards. Ensure adequate lighting conditions.
2. Do not wear loose fitting clothes, remove rings, wristwatch and bracelets. Tie back long hair.
3. Wear safety goggles and face shield if operation is dusty. Wear ear defenders.
4. Do not use the saw in a moist or wet environment, or in the vicinity of combustible liquids and gases.
5. The saw must only be operated with all correctly mounted guards.
6. Never use cracked or distorted saw blades. Only use sharp saw blades.
7. Use a pushing stick when rip sawing narrow work-piece.

3 Specification

Motor power (2HP)	220-240V,50Hz,1PH,1400RPM	
	380-400V,50Hz,3PH,1400RPM	
	110-120V,60Hz,1PH,1700RPM	
Sawblade speed	m/s	50Hz: 12;10
	m/s	60Hz: 14;12
Sawblade length	mm	2750
Sawblade width	mm	6-37
Worktable tilt		0-45°
Worktable size	mm	435x535
Max. cutting depth	mm	235
Max. cutting width	mm	345

4 Safety

4.1 General safety instructions

Before attempting to operate this machine, it is important that you read, understand and follow these instructions very carefully. They are designed for the safety of yourself and others ensuring a long and trouble free service life from your machine.

Safe Operation

Know Your Power Tool

It is important that you read and understand your instruction manual and any label attached to the power tool. Learn its applications as well as its limitations and the potential hazards associated with this power tool.

Work Area

Cluttered benches and work areas invite accidents. Workbenches should be kept tidy. Floors should be kept clean and free from rubbish. Special care should be taken where the floor is slippery due to sawdust or wax.

Work Environment

Do not expose your power tools to rain, or use in damp or wet locations. Keep the work area well lit. Do not use power tools in areas where there is a risk of explosion or fire from combustible materials, flammable liquids, paint, varnish, petrol etc. flammable gases and dust of an explosive nature. As a precaution it is recommended that you consult an expert on a suitable fire extinguisher and its use.

Guard Against Electric Shock

Avoid body contact with earthed or grounded surfaces (e.g. pipes, radiators, ranges, and refrigerators).

Beware Children and Pets

Children and pets should be kept out of the work area. Children should not be allowed to touch or operate machinery or touch extension cords. All power tools should be kept out of the reach of children, preferably stored or locked in a secure cabinet or room when not in use.

Do Not Force the Power Tool

The power tool will do a better and safer job and give you much better service if it is used at the rate for which it was designed.

Use the right tool

Select the right tool for the job. Do not use a tool for a job for which it was not designed. Do not force a small tool to do the job of a heavy-duty tool. Do not use tools for purposes not intended, for example do not use a circular saw to cut tree limbs or logs.

Personal safety

Clothing

Do not wear loose clothing, jewellery or anything that could get caught in moving machinery.

Hair

Long hair should be tied back or contained in a protective covering.

Eye Protection

The use of safety goggles is a mandatory requirement (normal glasses are not sufficient for eye protection). Prescription spectacles do not have safety lenses.

Ear Protection

Ear protection is advised during periods of extended operation.

Footwear

Where there is a risk of heavy objects damaging feet or if there is a risk of slipping on wet or slippery floors suitable non-slip safety footwear should be worn.

Head Protection

Where there is a risk of falling objects or hitting your head on protruding or low level obstructions a hard hat should be worn.

Respiratory Protection

When the machining operation creates dust, wear dust mask. When machining concrete, man made fibre boards, especially MDF (Medium Density Fibre Board) the resin used in these materials can be hazardous to your health. Use an approved face mask with replaceable filter.

Dust Extraction Equipment

If the machine is fitted with dust extraction and collection facilities ensure that these are properly connected and used.

Do Not Abuse the Power Cord

Never yank or pull on the power cord to disconnect it from the mains supply socket. Never carry your power

tool by its power cord. Keep the power cord away from heat, oil, solvents and sharp edges. If the power cord becomes damaged have it replaced by an authorised service facility.

Secure the Work Piece

Wherever possible secure the work piece using clamps or a vice. It is safer than using your hand and leaves both hands free to control the power tool.

Do Not Over-reach

Do not over-reach, keep proper footing and maintain your balance at all times.

Maintain Tools with Care

Keep cutting tools sharp and clean for better and safer performance.

Follow the instructions for lubricating and changing accessories.

Check the tool power cord periodically and if damaged have it replaced by an authorised service facility.

Inspect extension cords periodically and if damaged replace it.

Keep handles dry, clean and free from oil and grease.

Ensure that ventilation slots are kept clean and free from dust at all times. Blocked ventilation slots can cause overheating and damage to the motor.

Disconnect Power Tools

Ensure that power tools are disconnected from the mains supply when not in use, before servicing, lubricating or making adjustments and when changing accessories such as blades, bits and cutters.

Remove Adjusting Keys and Wrenches

Form the habit of always checking to see that keys and adjusting wrenches are removed from the power tool before turning it on.

Avoid Unintentional Starting

Ensure that the switch is in the OFF position before plugging the power tool into the mains supply.

Extension Cords and Reels

DO NOT use 2 core extension cords or reels on power tools with an earth path. Always use a 3 core extension cord or reel with the earth core connected to earth.

When the power tool is to be used outdoors, use only extension cords intended for outdoor use and are so marked.

Always unwind any extension cords fully.

For extension cords upto 15 metres use a wire cross section of 1.5mm².

For extension cords over 15 metres but less than 40 metres use a wire cross section of 2.5mm².

Always replace a damaged extension cord before using it. Protect your extension cord from sharp objects, excessive heat and damp or wet locations.

Stay Alert

Watch what you are doing, use common sense, and do not operate the power tool when you are tired, if taking medication that causes drowsiness, when having consumed alcohol or taken drugs.

Check Damaged Parts

Before using the power tool it should be carefully checked to determine that it will operate properly and perform its intended function.

Check for the correct alignment of moving parts ensuring they do not bind. Check for broken or missing parts and have them replaced or repaired at an authorised service centre. If the power tool requires mounting make sure it is securely attached to a suitable work bench. Check any other condition that may affect the operation of the power tool.

A guard or any other part of the power tool that is damaged should be properly repaired or replaced by an authorised service centre unless otherwise indicated in this instruction manual.

Any switch that does not operate correctly must be replaced by an authorised service centre.

Do not use the power tool if the ON/OFF switch does not turn the power tool ON and OFF.



Warning!

Do not attempt to modify the power tool in any way. The use of any attachment or accessory other than those recommended in this instruction manual could result in damage to the power tool and injury to the operator.

Have your power tool repaired by a qualified person.

This electric power tool complies with national and international standards and safety requirements.

Repairs should only be carried out by qualified persons using original spare parts. Failure to do so may result in considerable danger to the user.

Protect Furnishings

If using the power tool inside your house protect furnishings and floors with a suitable dust sheet.

Fire Precautions

When using certain power tools inside your house or workshop general fire precautions should be observed. As a precaution it is recommended that an expert is consulted on obtaining and using a suitable fire extinguisher.

4.2 Specific safety instructions for band saw

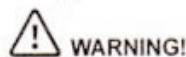

WARNING!
Some wood and wood type products, especially MDF (Medium Density Fibreboard) can produce dust that can be hazardous to your health. We recommend the use of an approved face mask with replaceable filters when using this machine in addition to using the dust extraction facility.

Approved safety glasses or goggles and ear defenders must be worn when using the power tool for prolonged periods.

Ensure that power tools are disconnected from the mains supply when not in use, before servicing, lubricating or making adjustments and when changing accessories such as blades.

Ensure that the band saw is securely fastened to its base and wherever possible secure the base to the floor. When selecting a location for the band saw consideration needs to be given to the size of material to be cut and the area around the BandSaw

Do Not attempt to use for wet cutting operations a fatal electric shock could occur. This machine is to be used for dry cutting only.

Do Not over tension the drive belt. The drive belt will last longer if the tension is released after each use.

Do Not allow sawdust to build up around the motor or inside the machine. A build up of sawdust is a fire hazard.

Do Not stop the blade by forcing the work piece or by using sideways pressure.

Keep Guards in place and in good working order.

Always ensure that the blade guide rollers are set correctly.

Do Not start the machine with the blade in contact with the work piece.

Check the work piece for any protruding nails, screw heads or anything that could damage the blade.

Do Not attempt to modify the machine or its accessories in any way.

Do Not use excessive force when feeding the work piece to the blade. Feeding the work piece gradually will reduce wear on the machine and blade increasing its efficiency and operating life.

Blade Safety

Use only blades that are recommended by the manufacturer.

Do Not use blades that are deformed or have missing teeth. This is highly dangerous and could result in a serious accident to the operator and bystanders as well as damaging the machine.

Only use blades that are recommended by the supplier and that are in good condition.

Ensure that the directional arrow, if marked on the blade corresponds with the rotational direction of the motor. The teeth of the blade should always point downward when viewed from the front of the saw.

Always release the blade tension, when the machine is not in use.



Always wear gloves and eye protection when fitting or removing blades.

Always uncoil blades in spacious areas, away from other people.

Always keep looped blades secure with tie wires.

Always keep fingers away from moving blades.

4.3 Symbols used throughout these instructions

-  **Danger!**
Indicates risk of personal injury or severe material damage.
-  **Risk of electric shock!**
Risk of personal injury by electric shock.
-  **Drawing-in/trapping hazard!**
Risk of personal injury by body parts or clothing being drawn into the rotating saw blades.
-  **Caution!**
Risk of material damage.
-  **Note:**
Supplementary information.

5 Unpacking

 **Note:** make sure all items are accounted for before discarding any packaging material.

 **Warning:** to avoid injury, if any parts are missing, do not attempt to assemble the machine, do not plug in the power cord, do not turn the switch on until missing parts are obtained and installed correctly.

6 Troubleshooting



WARNING: FOR YOUR OWN SAFETY, ALWAYS TURN OFF AND UNPLUG THE MACHINE BEFORE CARRYING OUT ANY TROUBLESHOOTING.

TROUBLE	PROBABLE CAUSE	REMEDY
The machine does not work when switched on.	<ol style="list-style-type: none"> 1. No power supply. 2. Defective switch. 	<p>Check the cable for breakage. Contact your local dealer for repair.</p>
The blade does not move with the motor running.	<ol style="list-style-type: none"> 1. The quick release lever or blade tension handwheel has not been tightened. 2. The blade has come off one of the wheels. 3. The saw blade has broken. 4. The drive belt has snapped. 	<p>Switch off the motor, tighten the quick release lever or blade tension handwheel.</p> <p>Open the hinged door and check.</p> <p>Replace the blade. Replace the belt.</p>
The blade does not cut in a straight line.	<ol style="list-style-type: none"> 1. Fence for cutting not used. 2. Too fast feed rate. 3. The blade teeth are dull or damaged. 4. Blade guides not suitably adjusted. 	<p>Use a fence. Put light pressure on the workpiece & make sure the blade does not bend. Use a new blade.</p> <p>Adjust the blade guides (see the section on page 7).</p>
The blade does not cut, or cuts very slowly.	<ol style="list-style-type: none"> 1. The teeth are dull, caused by cutting hard material or long use. 2. The blade was mounted in the wrong direction. 	<p>Replace the blade, use a 6 T.P.I. blade for wood and soft materials. Use a 14 T.P.I. blade for harder materials. A 14 T.P.I. blade always cuts slower due to the finer teeth and the slower cutting performance. Fit the blade correctly.</p>
Sawdust builds up inside the machine.	<ol style="list-style-type: none"> 1. This is normal 	<p>Clean the machine regularly. Open the hinged door and remove the sawdust with a vacuum cleaner.</p>
Sawdust inside the motor housing.	<ol style="list-style-type: none"> 1. Excessive dust build-up on the machine exterior components. 	<p>Clean the ventilating slots of the motor with a vacuum cleaner. From time to time remove the sawdust to prevent it from being sucked into the housing</p>
The machine does not cut at 45 or 90 angles.	<ol style="list-style-type: none"> 1. The table is not at right angles to the blade. 2. The blade is dull or too much pressure was put on the workpiece. 	<p>Adjust the table.</p> <p>Replace the blade or put less pressure on the workpiece.</p>
The blade cannot be properly positioned on the blade wheels.	<ol style="list-style-type: none"> 1. The wheels are not in alignment. Defective bearing. 2. The blade tracking knob hasn't been properly adjusted. 3. Inferior blade. 	<p>Contact your local dealer for repair.</p> <p>Adjust the knob (see the section on page 6).</p> <p>Replace the blade.</p>

7 Assembly

7.1 Initial Assembly

This machine is supplied partly assembled. Prior to use, the following items to be fitted. Bandsaw Table, Rip Fence Guide, Guide Post Handwheel, Belt Tension Handwheel and Dust Port.

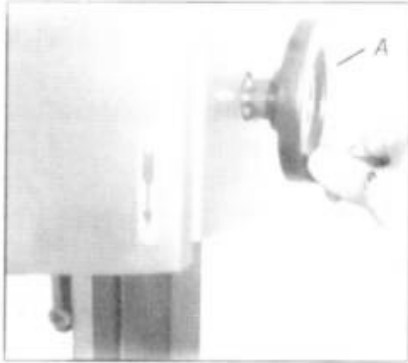

Fitting the guide post handwheel

Attach the guide post handwheel (A) to the shaft of worm gear with the M6x12 set screw.

Fitting the belt tension handwheel

Attach the belt tension handwheel (B) to the thread rod with the M6x12 set screw.

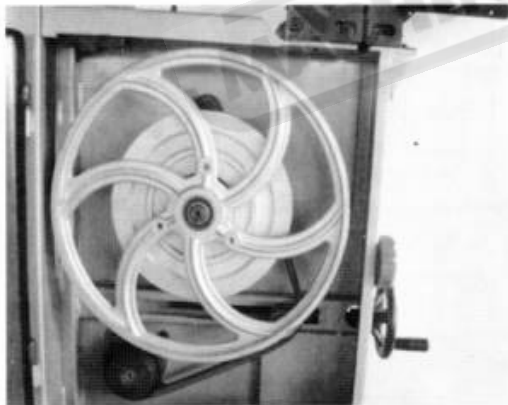

Fitting the table

Fit the table onto the table trunnion ensuring that the securing bolt is placed through the hole in the trunnion. Secure the table in place with 4-M8x16 (E) hex head bolts & 4-8mm washers.

Fit the rip fence guide

This instruction assumes that the blade is already fitted,

if not, go to the section headed "Replacing the bandsaw blade"

To fit the Rip Fence Guide (F) attach it to the front edge of the table with the four winged screws and washers(G) supplied. This will be adjusted later.

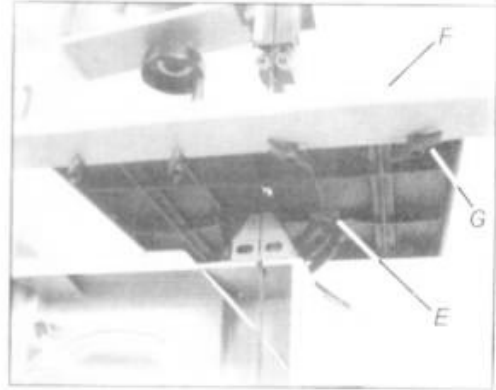

7.2 Setting Instructions

Warning! Before carrying out any maintenance or adjustments the machine must be disconnected from the power supply.

Setting up the table

Place a suitable set square against the table and the blade.

Loosen the table securing lock lever and adjust the table until it is at a right angle to the blade. Resecure the table. If necessary adjust the tilt scale(H) or the table stop screw(I) underneath the table.

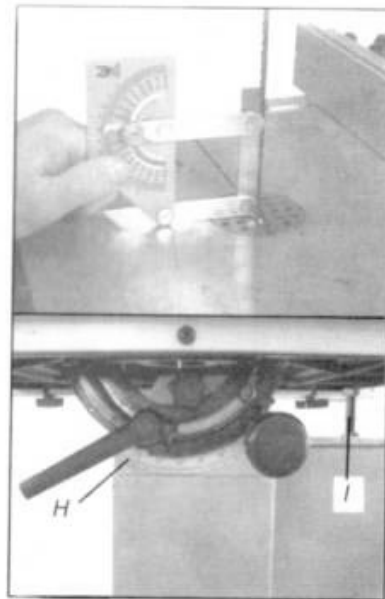

Setting up the blade tension & tracking

With the power supply disconnected, set the blade tension with the blade tension handwheel (J). Rotating the wheel in a clockwise direction will decrease the blade tension and anti clockwise will increase the tension. The blade is at the correct tension if it can be moved approximately 10 mm sideways with moderate hand pressure. Tension the blade until the tension readings corresponds to the width blade you are using through the tension indicator window.

Daily run you can through the blade tension window to check the tension of blade.

Daily run you can through the blade tracking window to check the tracking of blade.

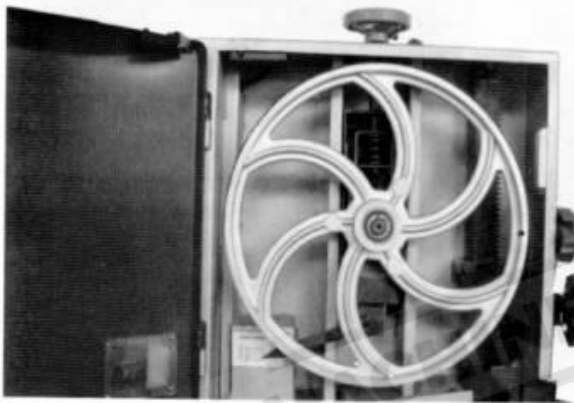
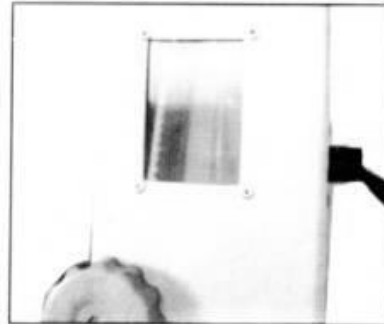

Tracking the saw blade

Firstly, make sure the upper and lower blade guides are adjusted away from the blade and the tension scale reading corresponds to the width blade you are using. Then loosen the lock lever (K) by turning it counterclockwise and turn the blade tracking knob (L) clockwise /counterclockwise while turning the upper wheel by hand at least three rotations until the blade tracks centered on the wheel.

Finally, tighten the lock lever and close the doors

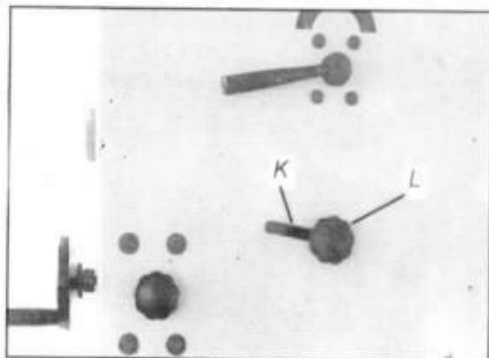

Setting up the blade guides

The blade guides minimise blade movement while making a cut.

The upper guide bearings and lower guide posts should be 0.5mm away from the sides of the blade. Position the rear thrust bearings approximately 3mm behind the blade. This will only come into contact with the blade as the work piece is cut.

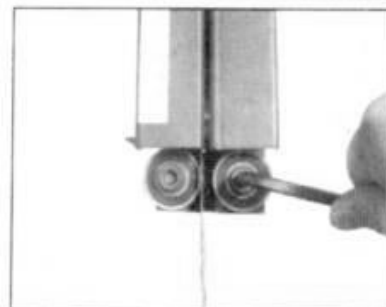
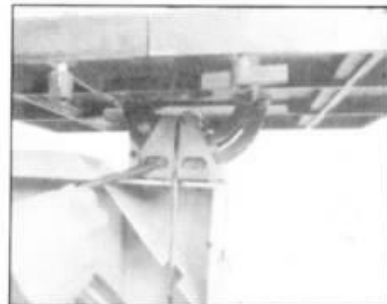
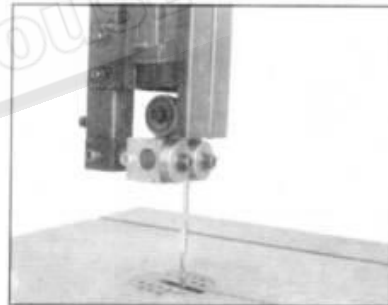

With the power supply disconnected rotate the blade wheel by hand ensuring that the blade does not catch on the guides.

NB. When using narrow blades (6mm) the lower rear blade support bearing needs to be in contact with the blade.

When wider blades are fitted it will be necessary to move the blade guide assemblies backwards to ensure the blade guides are always in the correct position.

To move the upper blade guide loosen the socket screw(M), slide the rod of upper guide to guide position is achieved.

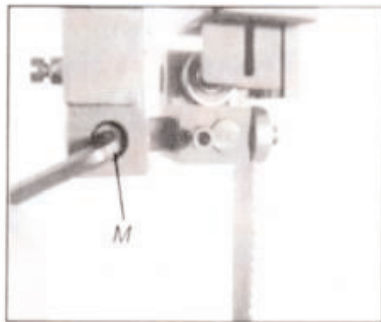

The lower blade guide is moved by loosening the socket screw(N), and turn the rear guide knob(O) to guide position is achieved.

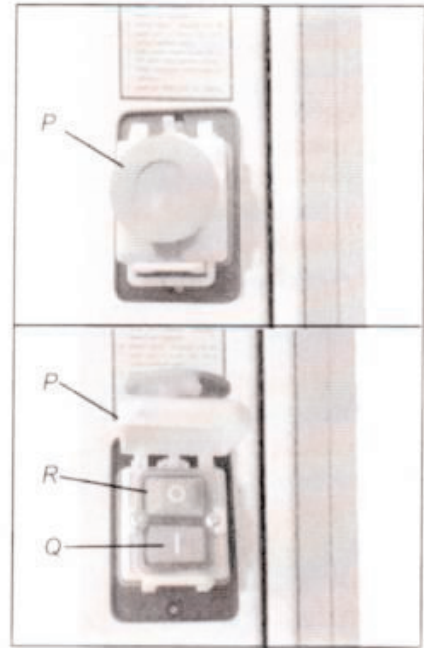
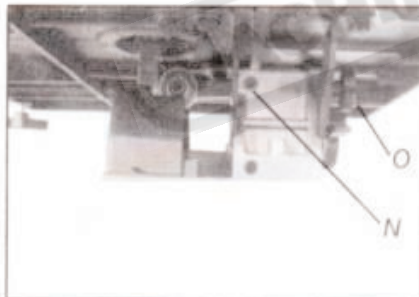

emergency stop cover(P) and press green the ON button(Q). To stop the machine, press the red OFF button(R). In the event of an emergency, hit the emergency stop cover(P), this will switch the machine OFF and will mechanically lock the emergency stop cover in place preventing the machine from being switched on until the mechanical lock has been released. To release the mechanical lock depress the emergency button and slide it upwards.

7.3 No Volts Emergency Stop Switch

This machine is fitted with a "No Volts Switch". In the event of a mains power failure or if the mains plug is removed from the mains supply socket before the machine is switched off. The machine will not re-start without warning when the mains supply is restored or the mains plug is re-connected to the mains supply, until the machine is switched ON at the ON/OFF switch fitted to the machine. The switch is also fitted with an emergency stop cover. To start the machine, lift the

8. Operating

8.1 Operating instructions

The upper blade guide assembly must be lowered to just clear of the work piece. To lower the assembly loosen the cut depth lock knob(T) and turn the guide post hand-wheel(U) to slide the upper guide assembly down. Re-secure the cut depth lock knob(T).



Set the rip fence to the desired width (ensure that the largest section of the material is against the fence)

Plan the cut before starting. Ensure that push sticks and other work aids are used when the work piece is too small to enable your hands to be kept clear of the blade. Before commencing a cut on a large work piece ensure that there is sufficient space around the saw for the movement of the piece. Also ensure that the piece is supported where necessary to avoid undue stress against the blade. Allow the material to be cut at a steady even pace. A clear sign that the work piece is being forced to be cut too quickly is the motor changing pitch or slowing down.

8.2 Using the mitre gauge

Make a practice cut with the gauge in the 0° position then test the cut with a suitable set square. If adjustment is necessary loosen the screw that holds the "pointer" and move the pointer accordingly. The mitre gauge can be used in either groove in the table. Set the desired angle on the mitre scale and make the cut securely holding the work piece to the mitre gauge.

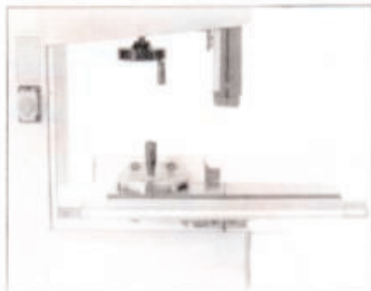

8.3 Tilting the table to perform bevel cuts

To use the table to perform a bevel cut, loosen the table trunnion locking lever(V) and turn the table tilt handle(W) to tilt the table over to the desired angle. Re-secure the locking lever(V). Compound mitre cuts can be made by using the mitre gauge in conjunction with the table tilting facility.

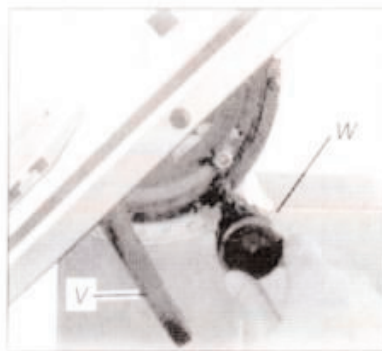

8.4 Making freehand and radius cuts

The general safety rules apply when making free hand cuts. It is advised that the rip fence is removed during these operations. The table below shows approximate radius that can be cut with which size of blade width.

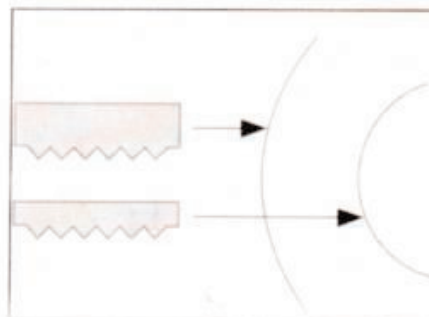

9 Adjustment & Maintenance

9.1 Changing the Blade Speed

 **Warning!** Before changing the speed always make sure the machine has been unplugged from the electrical supply

To change the speed of the blade, open the lower blade wheel cover. Fully slacken the belt tension by using the belt tension handwheel (X). Slowly rotate the blade wheel by hand and at the same time ease the drive belt off the largest motor pulley onto the smallest motor pulley. Using the same procedure move the drive belt from the smaller drive wheel pulley onto the largest drive wheel pulley.

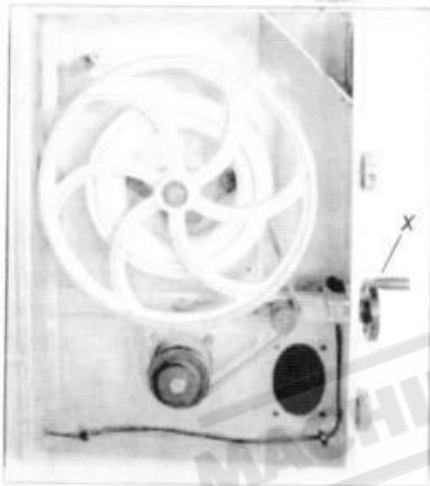

NB: The high blade speed is achieved when the drive belt is on the larger diameter drive pulley (motor).

9.2 Replacing the drive belt

Remove the blade (see changing the blade). Follow the procedure for changing the blade speed to release the belt tension. Carefully pull the belt off the machine, and replace the new belt over the drive blade wheel.



9.3 Changing the blade

 **Warning!** Unplug the machine from the electrical supply. This ensures that the bandsaw will not accidentally turn on if the ON/OFF switch is bumped.

Open both the upper and lower blade wheel covers. Remove the rip fence and guide from the table. Release the blade tension by rotating the quick release lever (Y) clockwise. Remove the saw blade from the machine taking great care to avoid the sharp teeth.



Caution: Because the blade is an endless loop it may spring and coil itself into smaller loops.

Replace the blade in the reverse manner ensuring that the teeth point downwards when viewed from the front of the machine.

Re-tension and track the blade in accordance with the pre operation instructions.

If necessary reset the blade guides in accordance with the pre operation instructions.

9.4 Maintenance

 **Caution!** Before cleaning or carrying out maintenance work, disconnect the machine from the power source (wall socket). Never use water or other liquids to clean the machine. Use a brush. Regular maintenance of the machine will prevent unnecessary problems.

Keep the table clean to ensure accurate cutting.

Keep the outside of the machine clean to ensure accurate operation of all moving parts and prevent excessive wear.

Keep the ventilation slots of the motor clean to prevent it from overheating.

Keep the inside (near the saw blade, etc.) clean to prevent accumulation of dust.

10 Wiring diagram



WARNING!

This machine must be grounded.

Replacement of the power supply cable should only be done by a qualified electrician.

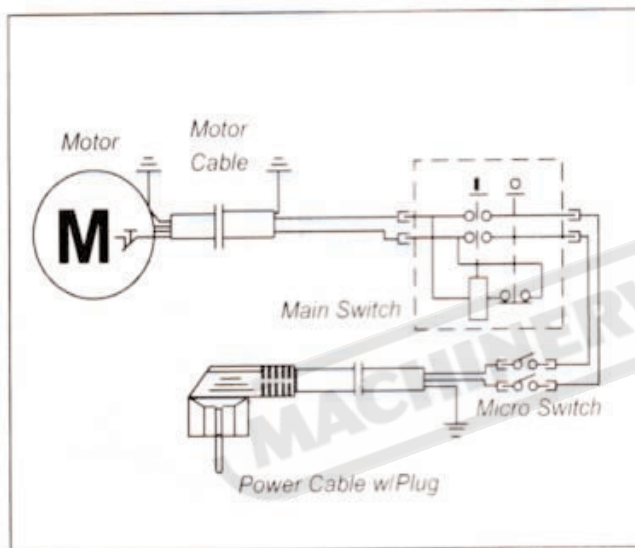

11 Troubleshooting



WARNING: FOR YOUR OWN SAFETY, ALWAYS TURN OFF AND UNPLUG THE MACHINE BEFORE CARRYING OUT ANY TROUBLESHOOTING.

TROUBLE	PROBABLE CAUSE	REMEDY
The machine does not work when switched on.	<ol style="list-style-type: none"> 1. No power supply. 2. Defective switch 	<p>Check the cable for breakage. Contact your local dealer for repair.</p>
The blade does not move with the motor running.	<ol style="list-style-type: none"> 1. The quick release lever or blade tension handwheel has not been tightened. 2. The blade has come off one of the wheels. 3. The saw blade has broken. 4. The drive belt has snapped. 	<p>Switch off the motor, tighten the quick release lever or blade tension handwheel.</p> <p>Open the hinged door and check.</p> <p>Replace the blade. Replace the belt.</p>
The blade does not cut in a straight line.	<ol style="list-style-type: none"> 1. Fence for cutting not used. 2. Too fast feed rate. 3. The blade teeth are dull or damaged. 4. Blade guides not suitably adjusted. 	<p>Use a fence. Put light pressure on the workpiece & make sure the blade does not bend. Use a new blade.</p> <p>Adjust the blade guides (see the section on page 7).</p>
The blade does not cut, or cuts very slowly.	<ol style="list-style-type: none"> 1. The teeth are dull, caused by cutting hard material or long use. 2. The blade was mounted in the wrong direction. 	<p>Replace the blade, use a 6 T.P.I. blade for wood and soft materials. Use a 14 T.P.I. blade for harder materials. A 14 T.P.I. blade always cuts slower due to the finer teeth and the slower cutting performance. Fit the blade correctly.</p>
Sawdust builds up inside the machine.	<ol style="list-style-type: none"> 1. This is normal 	<p>Clean the machine regularly. Open the hinged door and remove the sawdust with a vacuum cleaner.</p>
Sawdust inside the motor housing.	<ol style="list-style-type: none"> 1. Excessive dust build-up on the machine exterior components. 	<p>Clean the ventilating slots of the motor with a vacuum cleaner. From time to time remove the sawdust to prevent it from being sucked into the housing.</p>
The machine does not cut at 45 or 90 angles.	<ol style="list-style-type: none"> 1. The table is not at right angles to the blade. 2. The blade is dull or too much pressure was put on the workpiece. 	<p>Adjust the table.</p> <p>Replace the blade or put less pressure on the workpiece.</p>
The blade cannot be properly positioned on the blade wheels.	<ol style="list-style-type: none"> 1. The wheels are not in alignment. Defective bearing. 2. The blade tracking knob hasn't been properly adjusted. 3. Inferior blade. 	<p>Contact your local dealer for repair.</p> <p>Adjust the knob (see the section on page 6).</p> <p>Replace the blade.</p>

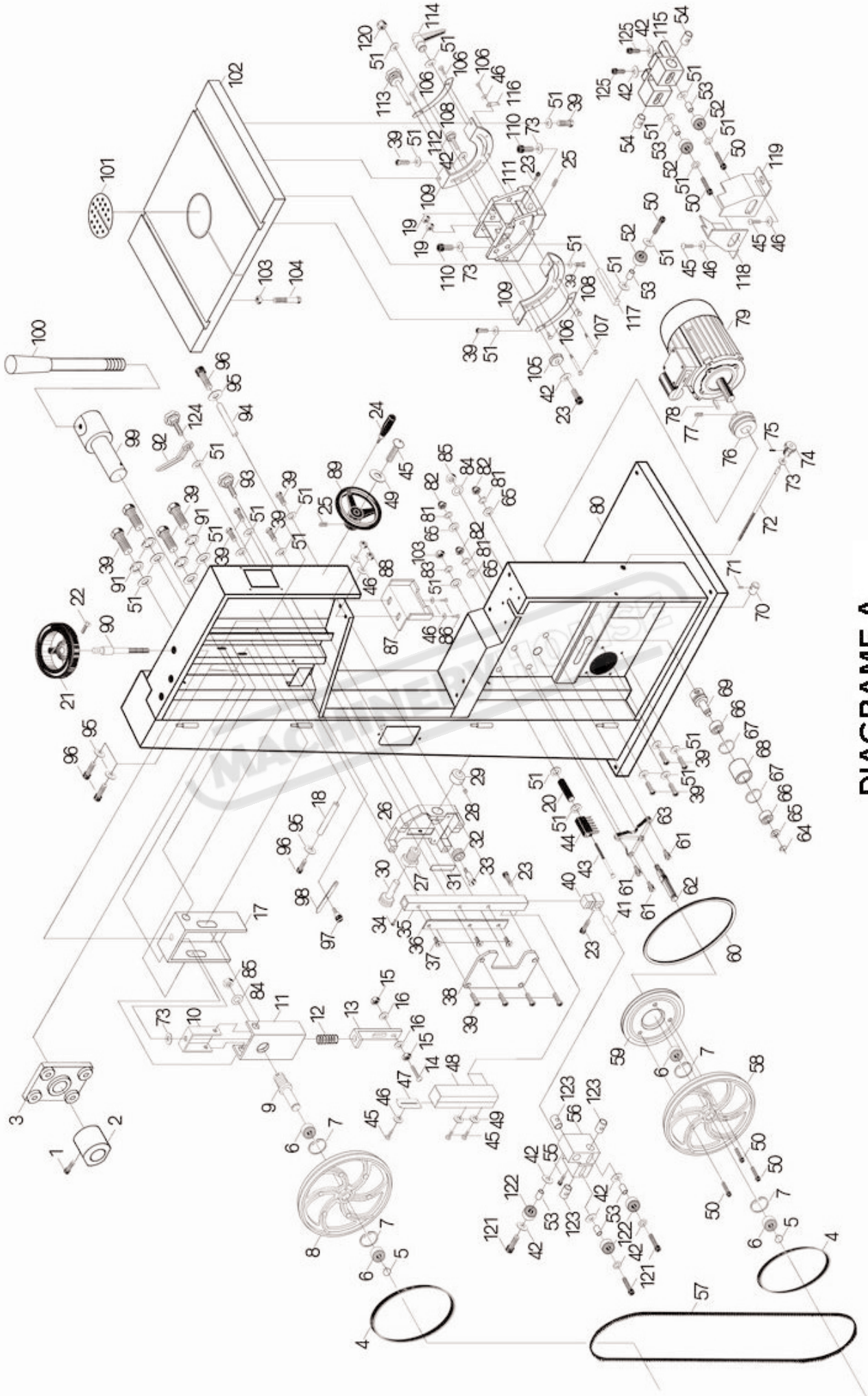

DIAGRAM A

PARTS LIST FOR DIAGRAM A

No.	DESCRIPTION	Qty	No.	DESCRIPTION	Qty
A-1	hexagon socket cap head screw M6×20	1	A-44	brush	1
A-2	lift eccentric	1	A-45	cross recessed pan head screw M5X10	6
A-3	eccentric block	1	A-46	washer 5	8
A-4	rubber belt	2	A-47	protective board	1
A-5	circlip for shaft d17	2	A-48	upper guide safety cover	1
A-6	bearing 80203	4	A-49	large washer 5	3
A-7	circlip for hole D40	4	A-50	hexagon socket cap head screw M8X28	6
A-8	upper wheel	1	A-51	washer 8	28
A-9	upper wheel shaft	1	A-52	bearing 80201	3
A-10	spring bracket	1	A-53	short bush for bearing	6
A-11	upper wheel shaft bracket	1	A-54	bearing nut	2
A-12	spring	1	A-55	hexagon socket cap head screw M6X16	1
A-13	bend board	1	A-56	bearing base for upper guide	1
A-14	cross recessed pan head screw M4X40	1	A-57	saw blade	1
A-15	hexagon nut M4	2	A-58	lower wheel	1
A-16	washer 4	2	A-59	belt wheel	1
A-17	upper wheel saddle	1	A-60	A-Type belt (900mm)	1
A-18	expand shaft for upper wheel	1	A-61	double-ended bolt	3
A-19	hexagon nut M6	2	A-62	lower wheel shaft	1
A-20	brush sleeve	1	A-63	big triangle bracket	1
A-21	handwheel	1	A-64	circlip for shaft d12	1
A-22	cross recessed pan head screw M6X16	1	A-65	washer 12	4
A-23	hexagon socket cap head screw M6X12	4	A-66	bearing 80101	2
A-24	swing handle for handwheel	1	A-67	circlip for hole D28	2
A-25	hexagon socket set screw M6X10	2	A-68	press wheel	1
A-26	guide pole frame	1	A-69	press wheel shaft	1
A-27	threaded sleeve	1	A-70	fix bush	1
A-28	slotted set screw M4X5	1	A-71	hexagon socket set screw M6X8	1
A-29	worm ring	1	A-72	press wheel rod	1
A-30	worm	1	A-73	washer 10	4
A-31	block	1	A-74	handle for press wheel	1
A-32	lift gear	1	A-75	spring type straight pin 3X20	1
A-33	lift gear nail	1	A-76	motor wheel	1
A-34	hexagon socket cap head screw M5X10	1	A-77	slotted set screw M5X10	1
A-35	guide square pole	1	A-78	key 6X6X40	1
A-36	rack	1	A-79	motor	1
A-37	cross recessed countersunk head screw M5X10	3	A-80	sawing body	1
A-38	cover board for guide pole	1	A-81	spring lock washer 12	3
A-39	hexagon head bolt M8X16	20	A-82	lid shape nut M12	3
A-40	guide pole connector	1	A-83	spring lock washer 8	1
A-41	shaft for bearing base	1	A-84	washer 16	2
A-42	washer 6	10	A-85	hexagon nut M16	2
A-43	step bolt M8X105	1	A-86	cross recessed pan head screw M5X16	2
			A-87	85° protective board	1

PARTS LIST FOR DIAGRAM A

No.	DESCRIPTION	Qty
A-88	hexagon nut M5	2
A-89	small handwheel	1
A-90	adjustable threaded rod	1
A-91	spring lock washer 8	4
A-92	lock handle nut	1
A-93	knob M8X95	1
A-94	quick lock shaft	1
A-95	large washer 6	4
A-96	hexagon socket cap head screw M6X12	4
A-97	pointer nail	1
A-98	pointer	1
A-99	eccentric shaft	1
A-100	eccentric threaded rod	1
A-101	insert	1
A-102	worktable	1
A-103	hexagon nut M8	2
A-104	hexagon head bolt M8X70	1
A-105	small gear	1
A-106	cross recessed pan head screw M5X6	5
A-107	step bolt M8X80	2
A-108	rack	2
A-109	worktable stand	1
A-110	hexagon socket cap head screw M10X30	2
A-111	rolling fixed frame	1
A-112	adjustable screw	1
A-113	small gear assembly	1
A-114	adjustable handle nut M8	1
A-115	lower guide frame	1
A-116	worktable pointer	1
A-117	bearing square rod	1
A-118	left safety cover	1
A-119	right safety cover	1
A-120	lock nut with plastic insert M8	1
A-121	hexagon socket cap head screw M6X25	3
A-122	bearing 8036	3
A-123	bearing nut	3
A-124	flower handle	1
A-125	hexagon socket cap head screw M6X20	1

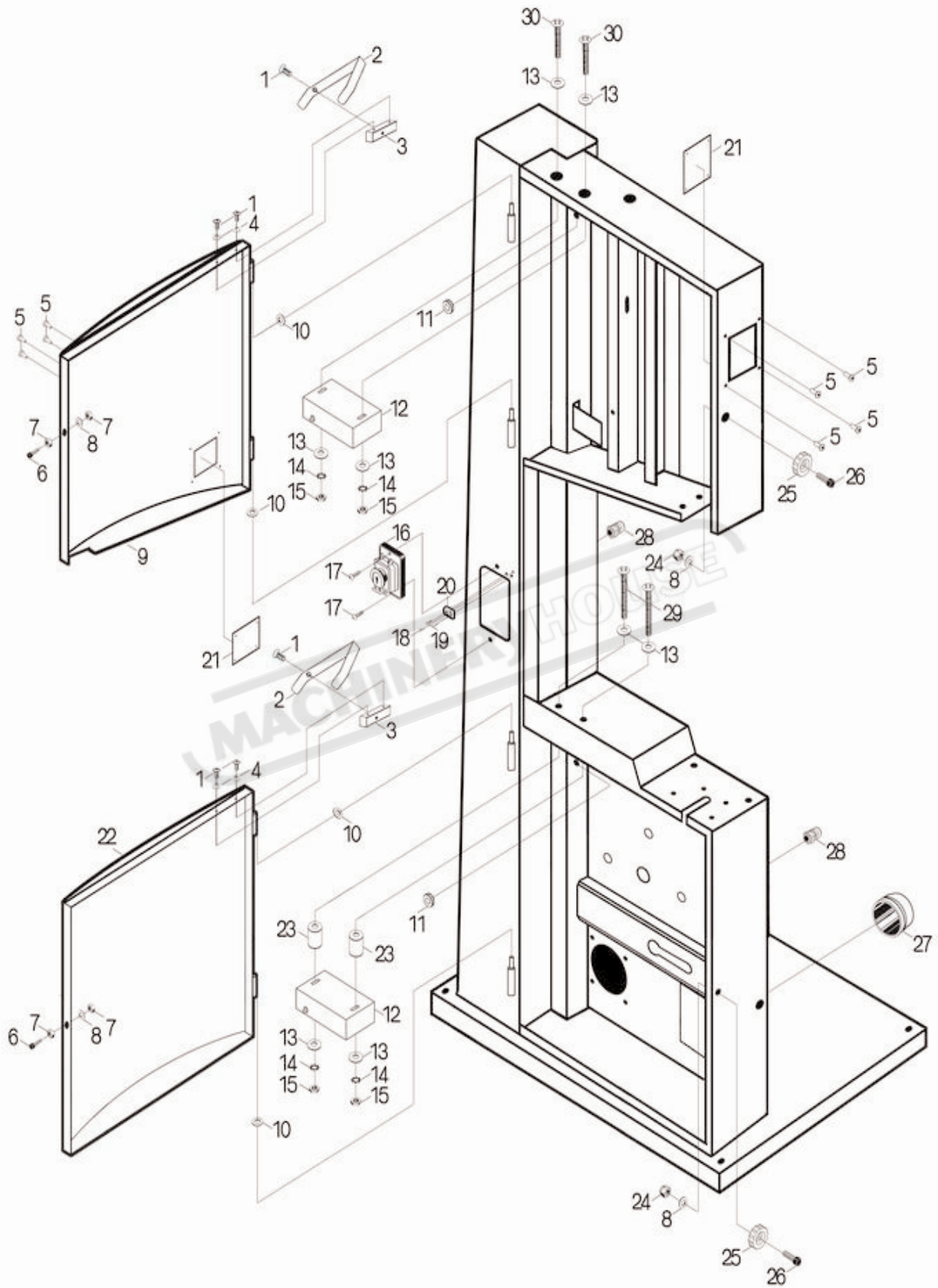

DIAGRAM B

PARTS LIST FOR DIAGRAM B

No.	DESCRIPTION	Qty
B-1	cross recessed pan head screw M5X10	6
B-2	spring leaf	2
B-3	spring leaf bracket	2
B-4	washer 5	4
B-5	rivet ϕ 4	6
B-6	hexagon socket cap head screw M6X20	2
B-7	hexagon nut M6	4
B-8	washer 6	4
B-9	upper door	1
B-10	copper washer 6	4
B-11	rubber sleeve	2
B-12	micro-switch	2
B-13	washer 4	8
B-14	external teeth lock washer 4	4
B-15	hexagon nut M4	4
B-16	switch	1
B-17	cross recessed pan head screw M4X12	2
B-18	rivet with small flat point ϕ 2X5	1
B-19	cross recessed pan head screw M4X6	2
B-20	earth-plate	1
B-21	plastic viewport	2
B-22	lower door	1
B-23	micro-switch sleeve	2
B-24	lock nut with plastic insert	2
B-25	knob	2
B-26	hexagon socket cap head screw M6X22	2
B-27	dust collect tube	1
B-28	strain relief	2
B-29	cross recessed pan head screw M4X25	2
B-30	cross recessed pan head screw M4X30	2

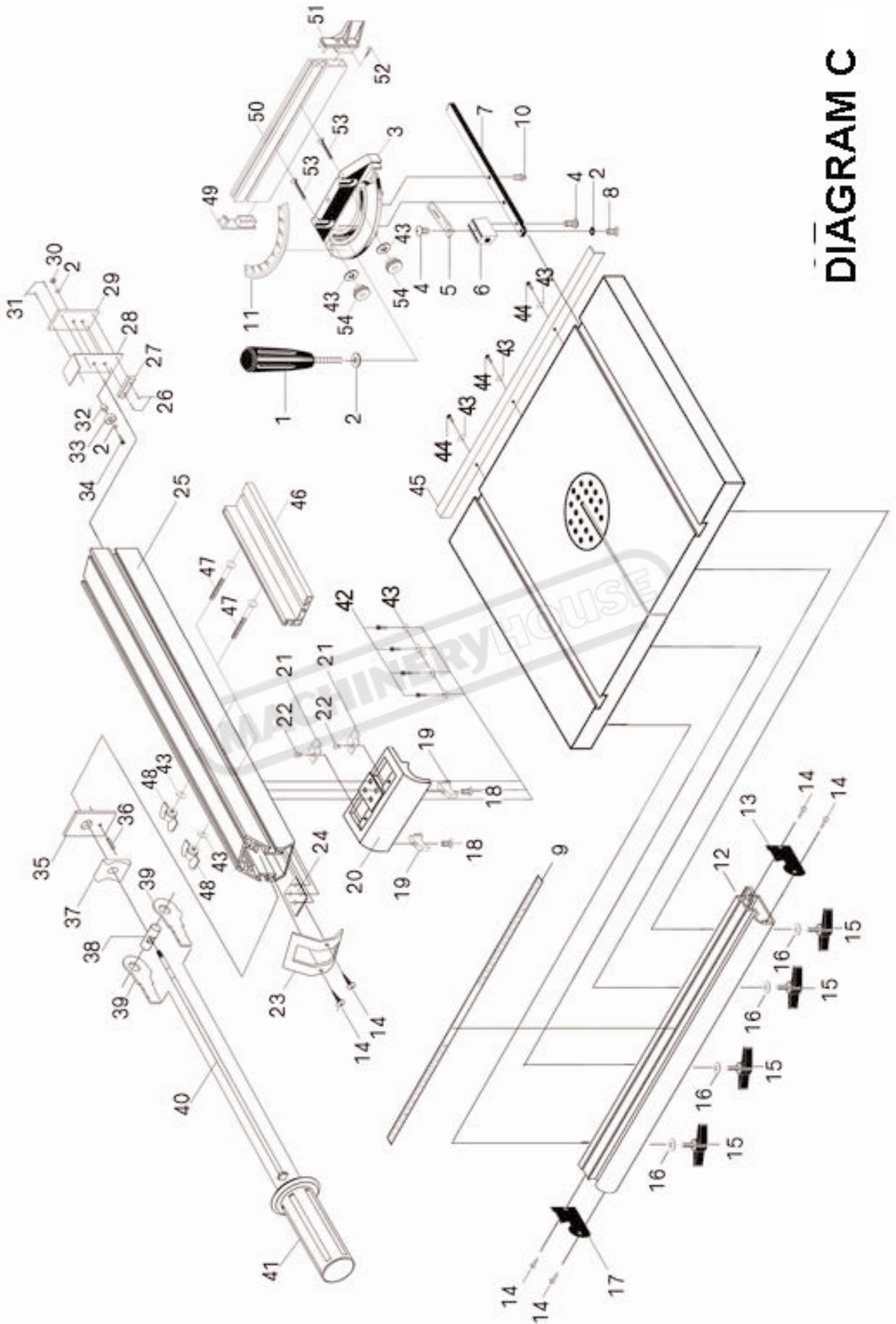

DIAGRAM C

PARTS LIST FOR DIAGRAM C

No.	DESCRIPTION	Qty	No.	DESCRIPTION	Qty
C-1	miter gauge knob	1	C-40	rip fence lock rod	1
C-2	flat washer 6	4	C-41	rip fence handle	1
C-3	dial	1	C-42	hexagon socket cap head screw M6x10	4
C-4	cross recessed pan head screw M5x10	2	C-43	flat washer 6	11
C-5	point	1	C-44	hexagon socket cap head screw M6x12	3
C-6	miter gauge block	1	C-45	rear rail	1
C-7	miter gauge rod	1	C-46	L-shape fence	1
C-8	cross recessed countersunk head screw M5X12	1	C-47	step bolt M6x70	2
C-9	Scale	1	C-48	wing nut	2
C-10	thread dowel	1	C-49	end cap B for dial fence	1
C-11	miter gauge scale	1	C-50	dial fence	1
C-12	front rail	1	C-51	end cap A for dial fence	1
C-13	right end cap	1	C-52	cross recessed countersunk head tapping screw 4.2X12	1
C-14	cross recessed pan head tapping screw M5X12	6	C-53	Step bolt M6x35	2
C-15	thumb screw	4	C-54	flower nut	2
C-16	flat washer 8	4			
C-17	left end cap	1			
C-18	cross recessed countersunk head screw 2 M5x10	2			
C-19	nylon block	2			
C-20	rip fence frame	1			
C-21	scale indicator	2			
C-22	cross recessed pan head tapping screw 2 M4x10	2			
C-23	rip fence cover	1			
C-24	nut board	1			
C-25	rip fence	1			
C-26	round head rivets with small head ϕ 3x13	2			
C-27	lock block	1			
C-28	lock spring	1			
C-29	lock plate	1			
C-30	selflock hexagon nut M6	1			
C-31	round head rivets with small head 3x7	2			
C-32	bearing bush	1			
C-33	bearing 80016	1			
C-34	hexagon socket cap head screw M6x24	1			
C-35	rip fence board	1			
C-36	spring-type straight pin 3x12	1			
C-37	rear block	1			
C-38	lock eccentric rod	1			
C-39	lock eccentric	2			

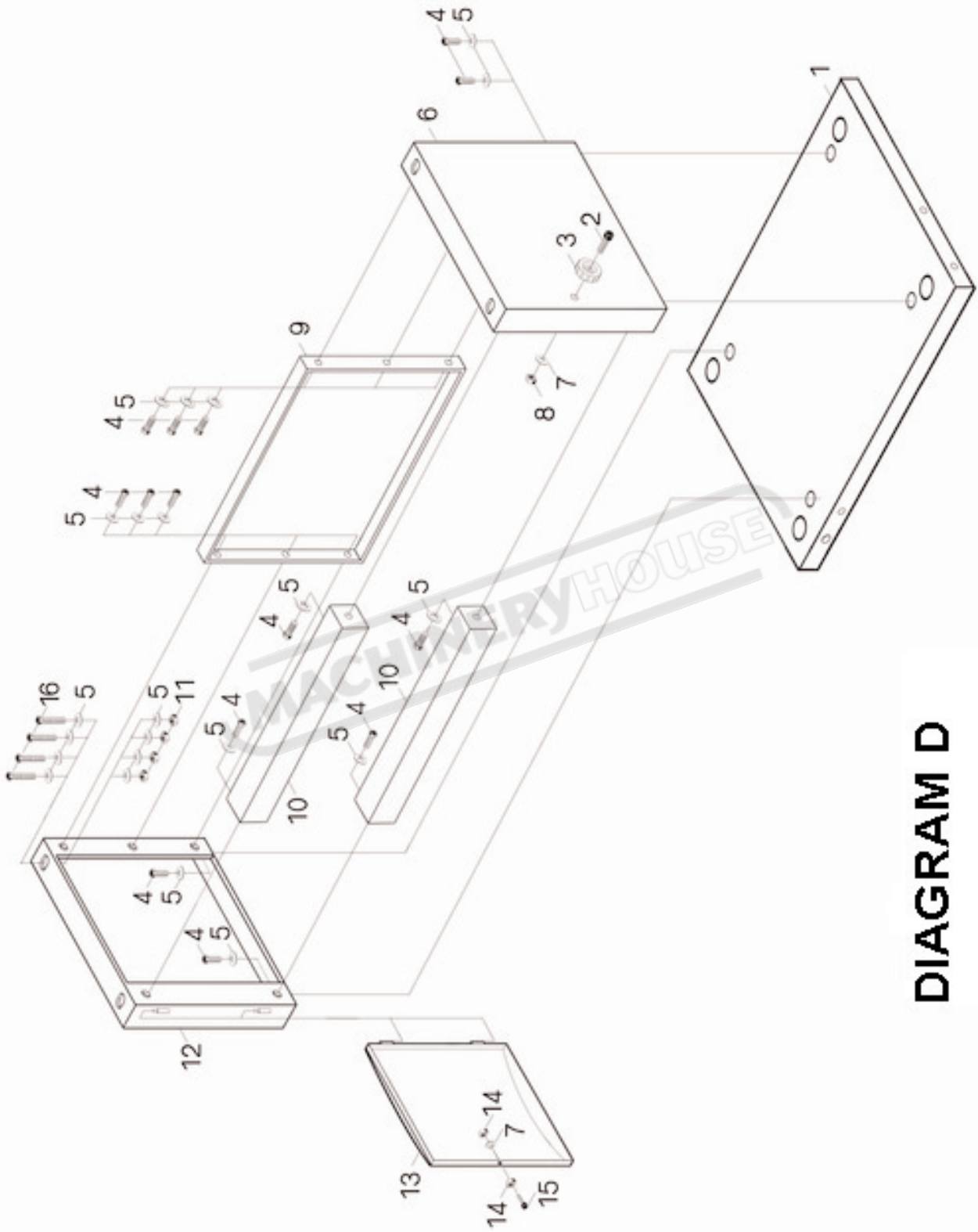

DIAGRAM D

PARTS LIST FOR DIAGRAM D

No.	DESCRIPTION	QTY
D-1	stand base	1
D-2	hexagon socket cap head screw M6x22	1
D-3	knob	1
D-4	hexagon screw M8x16	14
D-5	flat washer 8	22
D-6	right panel	1
D-7	flat washer 6	2
D-8	lock nut M6	1
D-9	rear panel	1
D-10	front support	2
D-11	hexagon nut M8	4
D-12	left panel	1
D-13	curve door	1
D-14	hexagon nut M6	2
D-15	hexagon socket cap head screw M6x20	1
D-16	hexagon socket cap head screw M8x50	4

MACHINERYHOUSE

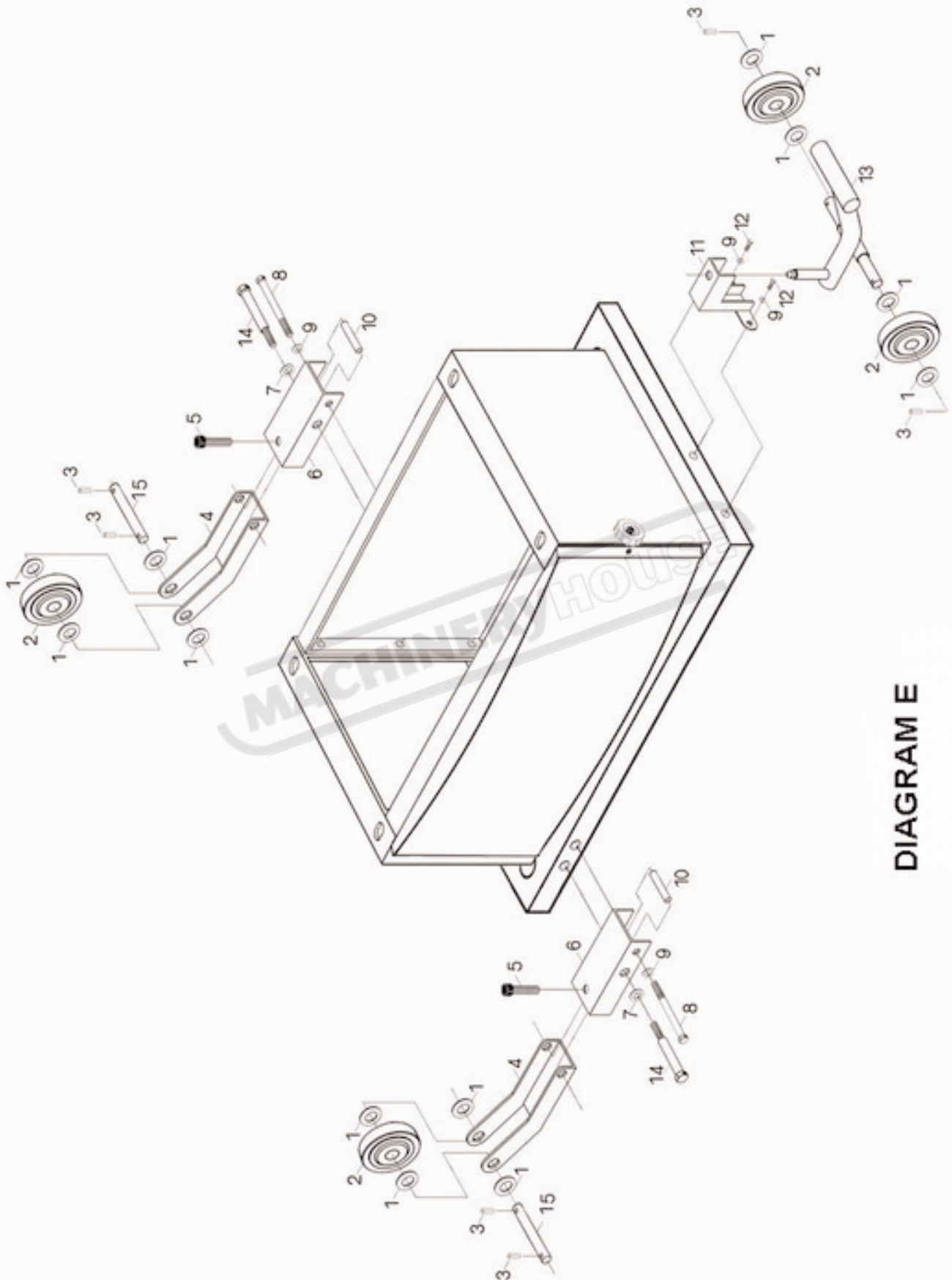

DIAGRAM E

PARTS LIST FOR DIAGRAM E

NO.	DESCRIPTION	QTY
E-1	Flat washer 16	12
E-2	Foot wheel	4
E-3	Split pin 4x22	6
E-4	Support for foot wheel	2
E-5	Hexagon socket cap head screw M12X50	2
E-6	Adjustable frame	2
E-7	Flat washer 14	2
E-8	Hexagon head bolt M10X70	2
E-9	Flat washer 10	4
E-10	Bush for adjustable frame	2
E-11	90° steel frame	1
E-12	Hexagon head bolt M10X20	2
E-13	Handle for foot wheel	1
E-14	Stop axle screw	2
E-15	single foot wheel shaft	2

MACHINERYHOUSE

**NOTE: NORMALLY, THIS ITEM OF BAND SAW DOES NOT INCLUDE FOOTWHEELS
THEY COULD BE SUPPLIED FOR YOUR ACCOUNT SEPARATELY IF NECESSARY!**